

StrapPack[®]

Semi-Automatic Strapping Machine



D-53



D-53 LB

D-53

D-53 Series

Semi-Automatic Strapping Machine



Variable and Consistent Tension

Stabilized Tensioning that is controlled with a microprocessor can easily be adjusted from 2kgf to 50kgf (4.4 lbs. to 110 lbs.) with a single dial. Tension is applied with a newly developed Steel Roller. In addition, the maximum Tension Range can be limited in order to prevent a damage of valuable package.

Seal Prolongation

Longer sealing time (plus 0.5 sec) for Heavy strap can easily be applied. (Option)

Desk-like Body

It provides a broad workspace and maximum foot room.

Small & Functional

Sealing head is located in the right side of the body in order to utilize the working surface of the tabletop. Machine body is small and light, easy to maneuver, yet strong and sturdy for heavy packages.

Quick Heater

Only requires 30 seconds to reach operating temperature.

High Speed Cycle

Cycle starts immediately after the strap is inserted into the Band Guide and completes the cycle faster than ever.

Strap Size

This model can be used with strap width ranging from 5mm (1/4 in.) to 12 mm (1/2 in.)

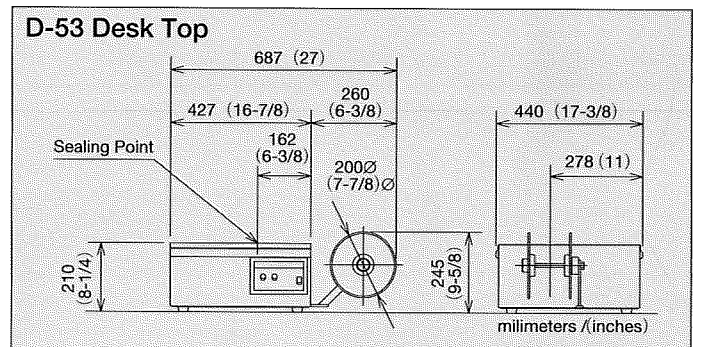
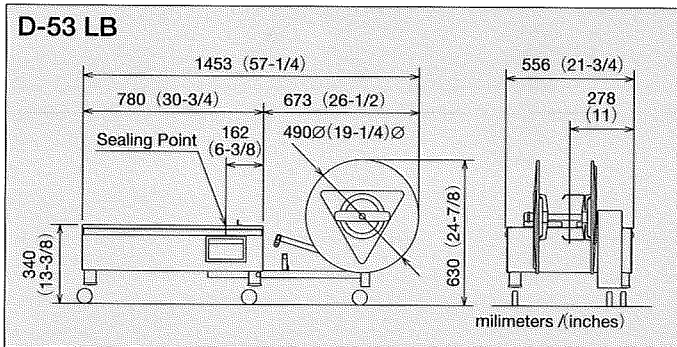
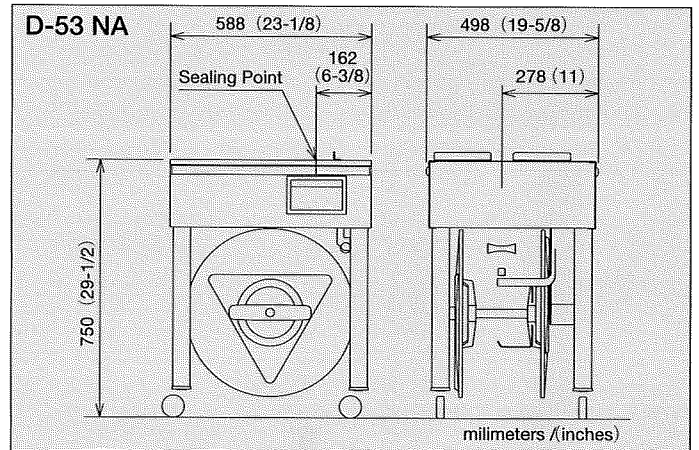
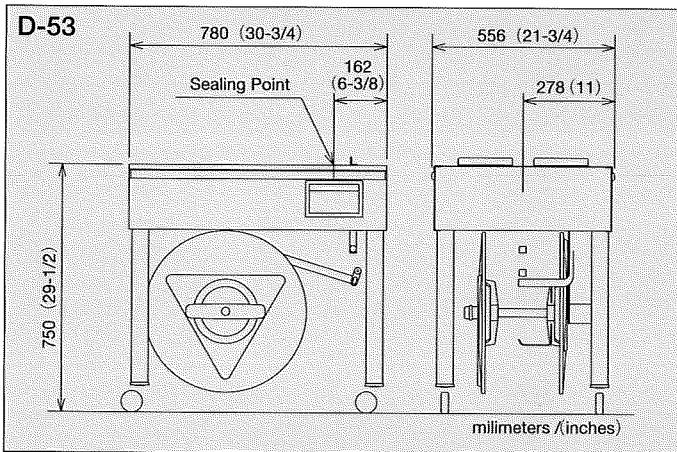

Standard Specifications

	D-53	D-53 LB	D-53 NA	D-53 Desk Top
Dimensions	width	780 (30-3/4)	width 1453 (57-1/4)	width 687 (27)
	depth	556 (21-3/4)	body width 780 (30-3/4)	body width 427 (16-7/8)
	table height	750 (29-1/2)	depth 556 (21-3/4)	depth 440 (17-3/8)
	height	775 (30-1/2)	table height 340 (13-3/8)	table height 210 (8-1/4)
Weight	50kg (110 lbs)	height 630 (24-7/8)	height 45kg (99 lbs)	height 245 (9-5/8)
Strap Tension	approx. 20 – 490N (2 – 50kgf)			
Package Size	width 100 (3-7/8) – free		height 30 (1-1/4) – free	
Strap Width	5, 6, 9 or 12 (1/4, 3/8 or 1/2)			
Power Supply	100, 220, 240V single phase 50/60Hz 0.4KVA			

Modification right reserved.

Pats., U.M. & design registered and/or pending.

© 2003 Strapack Corporation

DISTRIBUTED BY:

STRAPACK CORPORATION
 1-2-17, Higashi Shinbashi, Minato-ku, Tokyo 105-0021, JAPAN
 Phone 81-3-3289-1161 Fax. 81-3-3289-1160
 (URL) <http://www.strapack.com> (E-mail) info@strapack.com
STRAPACK INC.
 30860 San Clemente St. Hayward, CA 94544 U.S.A.
 Phone 1-510-475-6000 Fax. 1-510-475-6090
STRAPACK, N.V./S.A.
 Uilenbaan 200, 2160 Wommelgen, BELGIUM
 Phone 32-3-355-1520 Fax. 32-3-355-1521